

Product introduction

Description

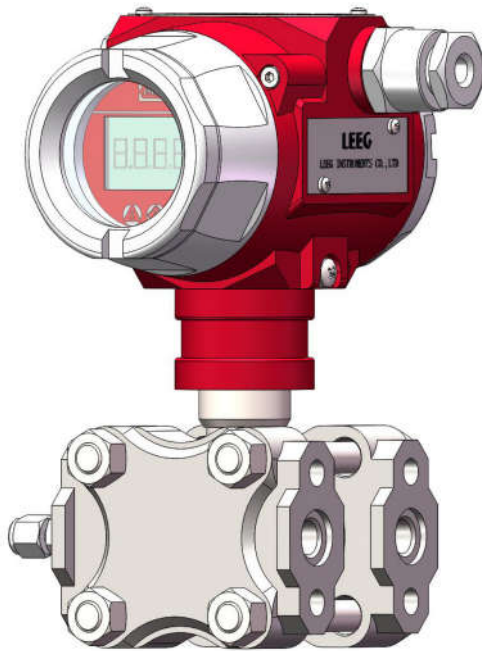

Monosilicon pressure transmitter

DMP305X monosilicon pressure transmitter is a high performance pressure transmitter with international leading technology meticulously designed by LEEG instrument, using the world's most advanced monosilicon pressure sensor technology and patent encapsulation technology.

Monosilicon pressure sensor locates on the top of the metal body and stay away from the medium interface to realizes mechanical isolation and thermal isolation. Glass sintering sensor wire realizes high strength electrical insulation of metal base and improves the capability of flexibility of electronic circuit and transient voltage resistance protection.

All these original encapsulation technologies enable DMP305X to easily cope with extreme chemical occasion and mechanical load, and own strong resistance to EMI, sufficient to respond to the most rigorous industrial environment applications, which are the genuine invisible instruments.

Main parameters

Pressure types	Differential pressure
Measuring range	200Pa - 10MPa, Please refer to the ordering information chapter
Output signal	4-20mA、4-20mA+HART, customer
Reference accuracy	±0.075% URL, optional ±0.05% URL

Measuring medium

Liquid, gas, or steam flow as well as liquid level, density and pressure

Field of application

Pressure, level, differential pressure, density, interface, flow

Approvals



Technical specifications

Measuring range and limit

Nominal value	Smallest calibratable span	Lower range limit (LRL)	Upper range limit (URL)	Static pressure limit	High pressure side overload limit	Low pressure side overload limit
6kPa	200Pa	-6kPa	6kPa	25MPa	25MPa	16MPa
40kPa	400Pa	-40kPa	40kPa	40MPa	25MPa	16MPa
250kPa	2.5kPa	-250kPa	250kPa	40MPa	25MPa	16MPa
1MPa	10kPa	-500kPa	1MPa	40MPa	25MPa	16MPa
3MPa	30kPa	-500kPa	3MPa	40MPa	25MPa	16MPa
10MPa	100kPa	-500kPa	10MPa	40MPa	25MPa	16MPa

Adjust requirements: lower range value (LRV) and upper range value (URV) can be adjusted within the scope of the upper and lower range limit, when $|URV| \geq |LRV|$, needs $|URV| \geq$ smallest calibratable span
 when $|URV| \leq |LRV|$, needs $|LRV| \geq$ smallest calibratable span

Standard specifications and reference conditions

Test standard: GB/T28474 / IEC60770; zero based-calibration span, linear output, silicon oil filling, 316L stainless steel isolated diaphragm.

Performance specifications

The overall performance including but not limited to **【Reference accuracy】**, **【Environment temperature effects】**, **【Static pressure effects】** and other comprehensive error
 Typical accuracy: $\pm 0.075\%$ URL
 Stability: $\pm 0.2\%$ URL/ 5 years

Reference accuracy

Including linearity, hysteresis and repeatability. calibration temperature: $20^{\circ}\text{C} \pm 5^{\circ}\text{C}$

Linear output accuracy	TD ≤ 10 (note 1)	$\pm 0.075\%$ URL	Nominal value
	$10 < \text{TD} \leq 100$	$\pm 0.0075\text{TD}\%$ URL	6kPa、40kPa 250kPa、1MPa 3MPa、10MPa

Square root output accuracy is 1.5 times linear output accuracy

Note 1: TD is Turn down,
 when $|URV| \geq |LRV|$, $\text{TD} = \text{URL} / |URV|$
 when $|URV| \leq |LRV|$, $\text{TD} = \text{URL} / |LRV|$

Ambient temperature effects

Within the range $-20-80^{\circ}\text{C}$ total impact $\pm(0.1+0.1\text{TD})\%$ URL

Static pressure effects

Effect on zero	$\pm 0.15\text{TD} \%$ URL/10MPa
Effect on full scale	$\pm 0.2\%$ URL/10MPa

Power supply effects

When power supply voltage is within 10.5/16.5-55VDC, zero and span change should not more than $\pm 0.005\%$ URL/V

Mounting position effects

Install error less than 400Pa, which can be corrected by PV=0 reset.

Vibration effects

According to IEC61298-3, $< 0.1\%$ URL

Output signal

Two wire 4-20 mA output with digital communications, linear or square root output programmable, HART protocol is superimposed on the 4-20mA signal.

Technical specifications

Damping time

Total damping time constant: equal to the sum of damping time of amplifier and sensor capsule
Damping time of amplifier : 0-100S adjustable
Damping time of sensor capsule (isolated diaphragm and silicon filling oil)≤0.2S
Startup after power off: ≤6S
Normal services after data recovery : ≤31S

Weight

Net weight: about 4 kg (without mounting bracket and process connection adaptor)
--

Environment condition

Items	Operational condition
Working temperature	-40-85°C, integrated LCD display: -20-70°C
Storage temperature	-40-110°C, integrated LCD display: -40-85°C
Media temperature	Silicon oil filling: -40-120°C
	Fluorocarbon oil filling: -45-160°C
Working humidity	5-100% RH@40°C
Protection class	IP67
Dangerous condition	ExialICT4(GYB16.1962X)*
	ExdIICT6(GYB16.1254X)*

*Please consult engineers for details

Power supply

Item	Operating conditions
Standard/flame proof	10.5-55VDC
HART protocol	16.5-55VDC, communication load resistance 250Ω
Load resistance	0-2119Ω for operation, 250-600Ω for HART protocol
Transmission distance	<1000 meters
Power consumption	≤500mW@24VDC, 20.8mA

Power supply and load requirements

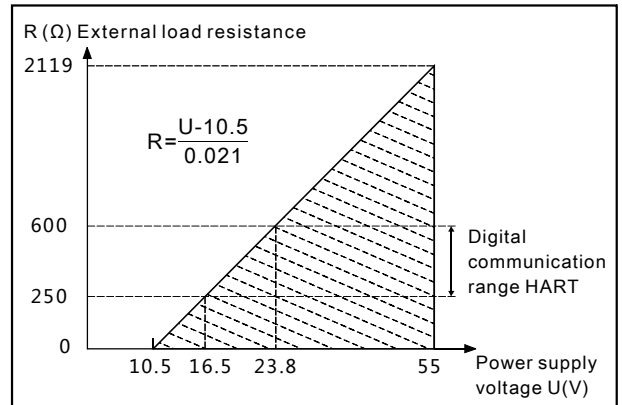

EMC environment

NO.	Test items	Basic standards	Test conditions	Performance level
1	Radiated interference	GB/T 9254/CISPR22	30MHz-1000MHz	OK
2	Conducted interference (DC power port)	GB/T 9254/CISPR22	0.15MHz-30MHz	OK
3	Electrostatic discharge immunity test (ESD)	GB/T 17626.2/IEC61000-4-2	4kV(Contact), 8kV(Air)	B(Note2)
4	Immunity to radio frequency EM-fields	GB/T 17626.3/IEC61000-4-3	10V/m(80MHz-1GHz)	A(Note1)
5	Power frequency magnetic field Immunity test	GB/T 17626.8/IEC61000-4-8	30A/m	A(Note1)
6	Electrical fast transient / Burst Immunity Test	GB/T 17626.4/IEC61000-4-4	2kV(5/50ns, 100kHz)	B(Note2)
7	Surge immunity requirements	GB/T 17626.5/IEC61000-4-5	1kV(Line to line) 2kV(Line to ground) (1.2us/50us)	B(Note2)
8	Immunity to conducted disturbances induced by radio frequency fields	GB/T 17626.6/IEC61000-4-6	3V(150kHz-80MHz)	A(Note1)

(Note 1) Performance level A: The performance within the limits of normal technical specifications.

(Note 2) Performance level B: Temporary reduction or loss of functionality or performance, it can restore itself. The actual operating conditions, storage and data will not be changed.

Disclaimer: all the data used in the product description is not legally binding. Relevant technical details may be changed due to further improve

Menu function

Specific menu

Transmission module type

Output signal	Local control	Remote control
4-20mA+HART	LCD/3 buttons on body	HART
4-20mA	LCD/3 buttons on body	-

LCD display unit

Display mode	Details
PV	Process variable shows on main screen, percentage and progress bar shows on secondary screen
mA	Current shows on main screen, percentage and progress bar shows on secondary screen
%	Percentage shows on main screen, percentage and progress bar shows on secondary screen

Unit

Unit	Definition
kPa	Kilopascal
MPa	Megapascals
bar	Bar
psi	Pounds per square inch
mmHg	Millimetre(s) of mercury@0°C
mmH2O	Millimeter of water@4°C
mH2O	Meter of water@4°C
inH2O	Inches of water@4°C
ftH2O	Feet of water@4°C
inHg	Inches of mercury@0°C
mHg	Meter mercury column@0°C
TORR	Torr
mbar	Millibar
g/cm2	Gram per square centimeter
kg/cm2	Kilogram per square centimeter
Pa	PA
ATM	Standard atmospheric pressure
mm	Millimeter(Note1)
m	Meter(Note1)
Note1: length unit need mark medium density	

Measuring menu set

Mark	State
URV	Upper range value, 20mA
LRV	Lower range value, 4mA

Damping time

Units	Setting range
S	0-100

Analog output type

Parameters	Output type
mA LINER	Linearity
mA $\sqrt{\quad}$	Square root

Alarm signal

Parameters	Alarm signal
ALARM NO	None
ALARM H	20.8mA
ALARM L	3.8mA

Fix output

Parameters	Fix output value
FIX/C NO	None
3.8000	3.8000mA
4.0000	4.0000mA
8.0000	8.0000mA
12.000	12.000mA
16.000	16.000mA
20.000	20.000mA
20.800	20.800mA

Quick menu

Parameter	Instruction
PV=0	Set current output to zero value, used to correct the error caused by static pressure and installation.
Zero adjustment	4mA re-range with pressure
Span adjustment	20mA re-range with pressure
Restore factory setting	Restore backup data when error

Disclaimer: all the data used in the product description is not legally binding. Relevant technical details may be changed due to further improve

Product selection instruction

Sensor select instruction

Code	Nominal value	Description
S602D	6kPa	Range -6-6kPa, smallest calibratable span 200Pa
S403D	40kPa	Range -40-40kPa, smallest calibratable span 400Pa
S254D	250kPa	Range -250-250kPa, smallest calibratable span 2.5kPa
S105D	1MPa	Range -0.5-1MPa, smallest calibratable span 10kPa
S305D	3MPa	Range -0.5-3MPa, smallest calibratable span 30kPa
S106D	10MPa	Range -0.5-10MPa, smallest calibratable span 100kPa

Code	Position	Instruction
S	Diaphragm material	SUS316L
H		Hastelloy C
S	Fluid filling	Silicon oil, process temperature: -45-205°C
D		Fluorocarbon oil, process temperature: -45-160°C
S	Sensor seal	O-ring, FKM, process temperature: -20~200°C

Diaphragm(S/H)



Seal(S)

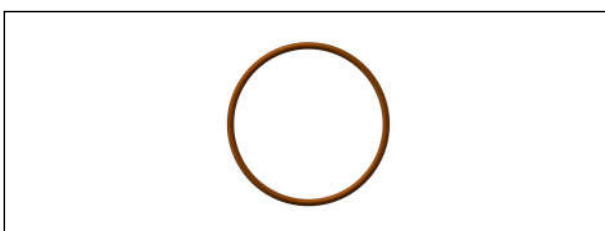

Electrical connection select instruction

Code	Item	Description
T1	Electrical connection	Aluminum-alloy terminal, 2 cable entry M20*1.5(F), red body, white cover
R1	Cable entry protector	Waterproof connector M20X1.5 one side, blind plug another side, PVC material, 6-8mm diameter cable only, IP67
R2		Flame proof, 1/2 NPT(F) one side, blind plug another side, stainless steel material, 6-8mm diameter cable only, IP67
R3		Flame proof, M20X1.5(F) one side, blind plug another side, stainless steel material, 6-8mm diameter cable only, IP67

Housing (T1)

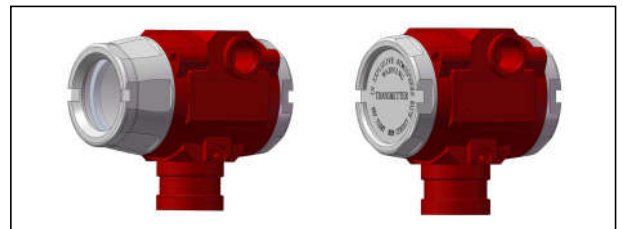

Standard cable entry protective adaptor(R1)

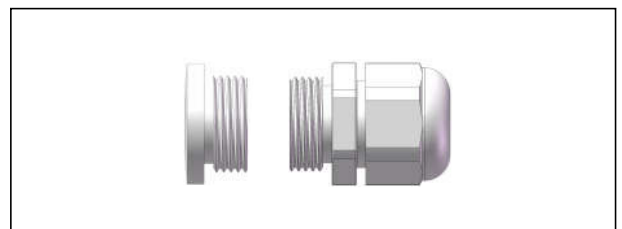

Flame proof cable entry protective adaptor(R2/R3)

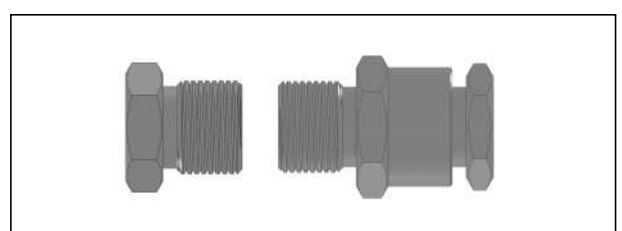

Product selection instruction

Transmission module

Code	Items	Description
F	Output signal	4-20mA two wire, power supply: 10.5-55VDC
H		4-20mA+HART two wire, power supply: 16.5-55VDC
A	Display	Without display
C		With LCD display

Display module(C)



Terminals (N1)

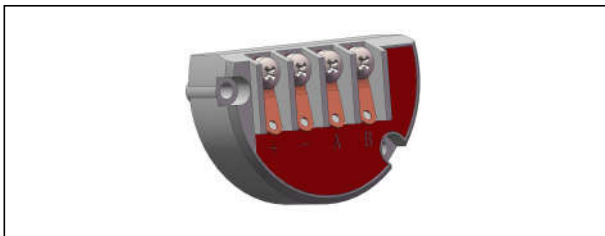

Process connection selection

Code	Item	Description
H1	Flange/ Drain Valve	H structure, double flanges, process connection 1/4-18NPT(F), drain valve on the rear end of flange, material SS 316
H2		H structure, double flanges, process connection 1/4-18NPT(F), drain valve on the up part of flange, material SS 316
H3		H structure, double flanges, process connection 1/4-18NPT(F), drain valve on the down part of flange, material SS 316

Flange

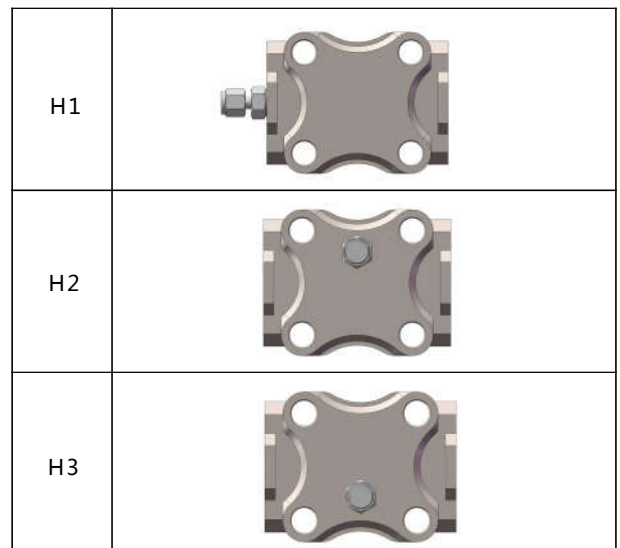

Wetted parts

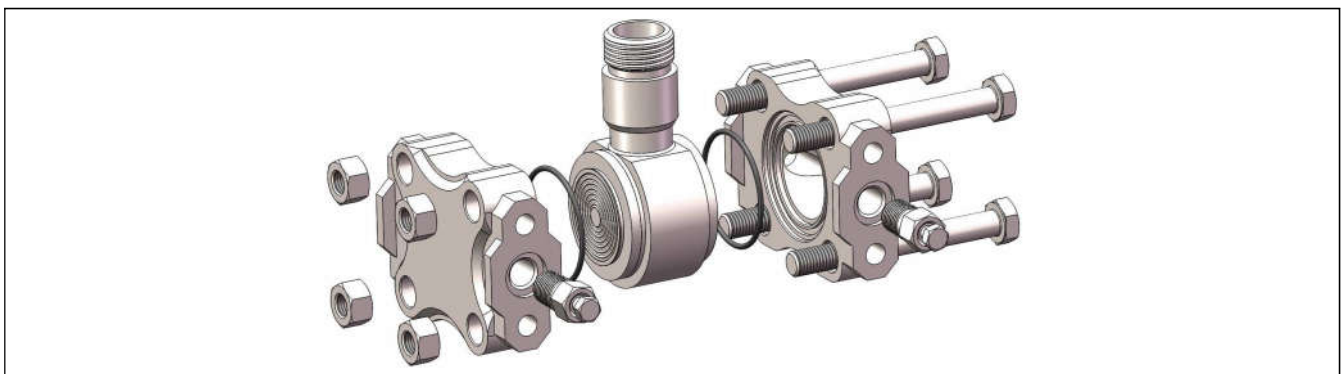

Disclaimer: all the data used in the product description is not legally binding. Relevant technical details may be changed due to further improve

Product selection instruction

Process connection adaptor

Code	Item	Description
A1	Process connection adaptor	Adaptor, M20*1.5 (M) with pressure-guided pipe $\Phi 14*2*30$, SS304, apply to H-structure
A2		Adaptor, 1/2-14NPT(F), SS 304, apply to H-structure

Adaptor, M20*1.5 (M) with pressure-guided pipe(A1)



Adaptor, 1/2-14NPT(F) (A2)



Brackets

Code	Items	Details
B1	Fixed mounting	Pipe mounting bent bracket, 2" pipe, carbon steel, apply to H-structure
B2		Plate mounting bent bracket, carbon steel, apply to H-structure
B3		Pipe mounting flat bracket, 2" pipe, carbon steel, apply to H-structure

Pipe mounting bent bracket(B1)

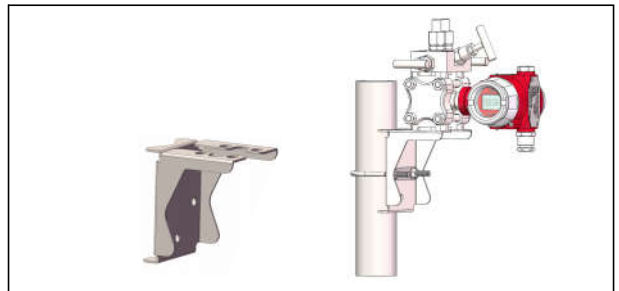
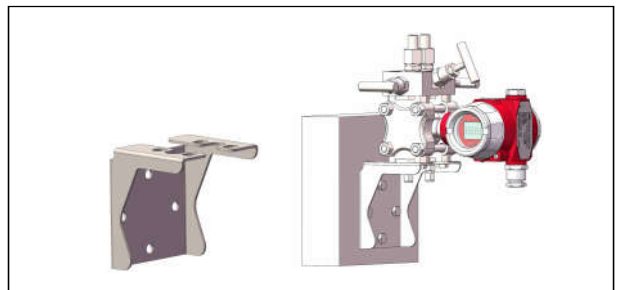
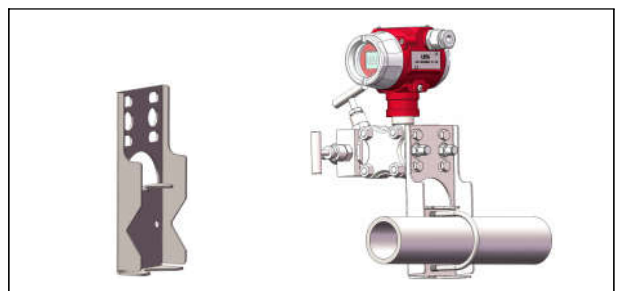

Plate mounting bent bracket(B2)



Pipe mounting flat bracket(B3)



Product drawing and dimension

Drawing and dimension with display(C)(unit:mm)

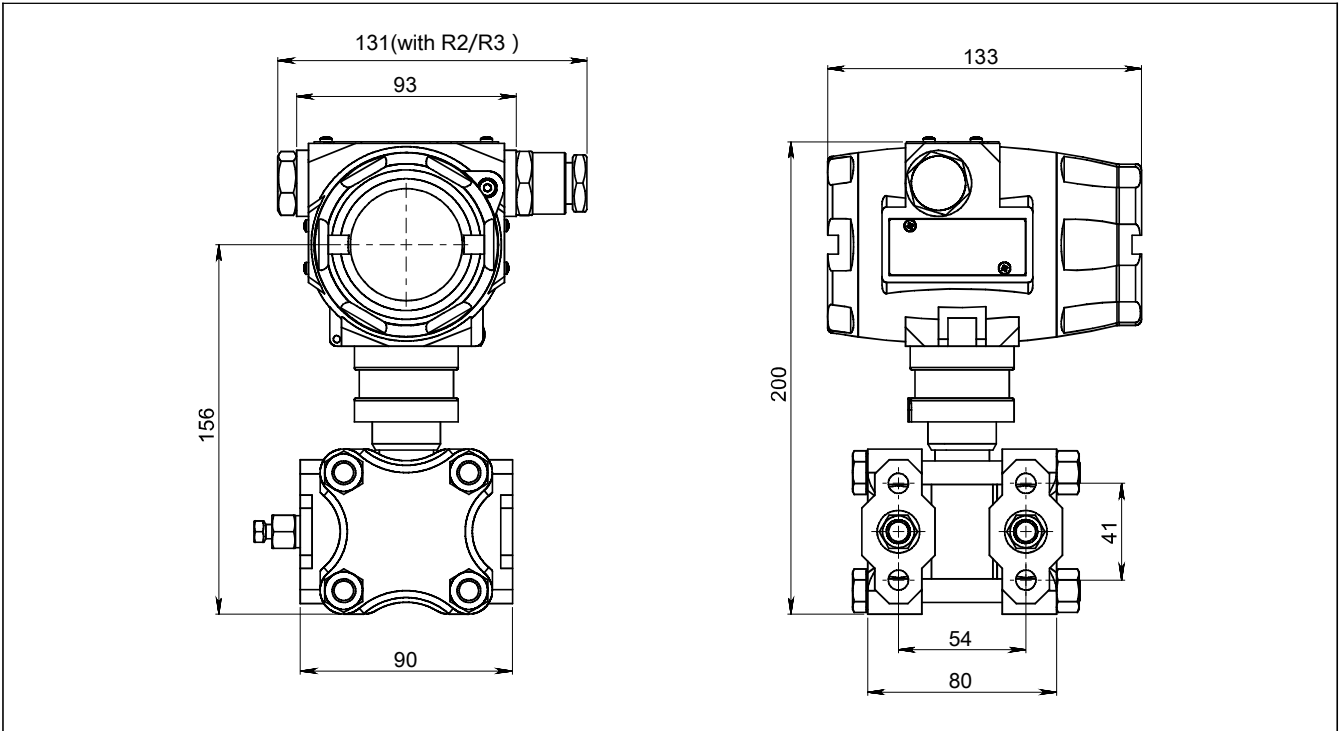

Drawing and dimension without display(A)(unit: mm)

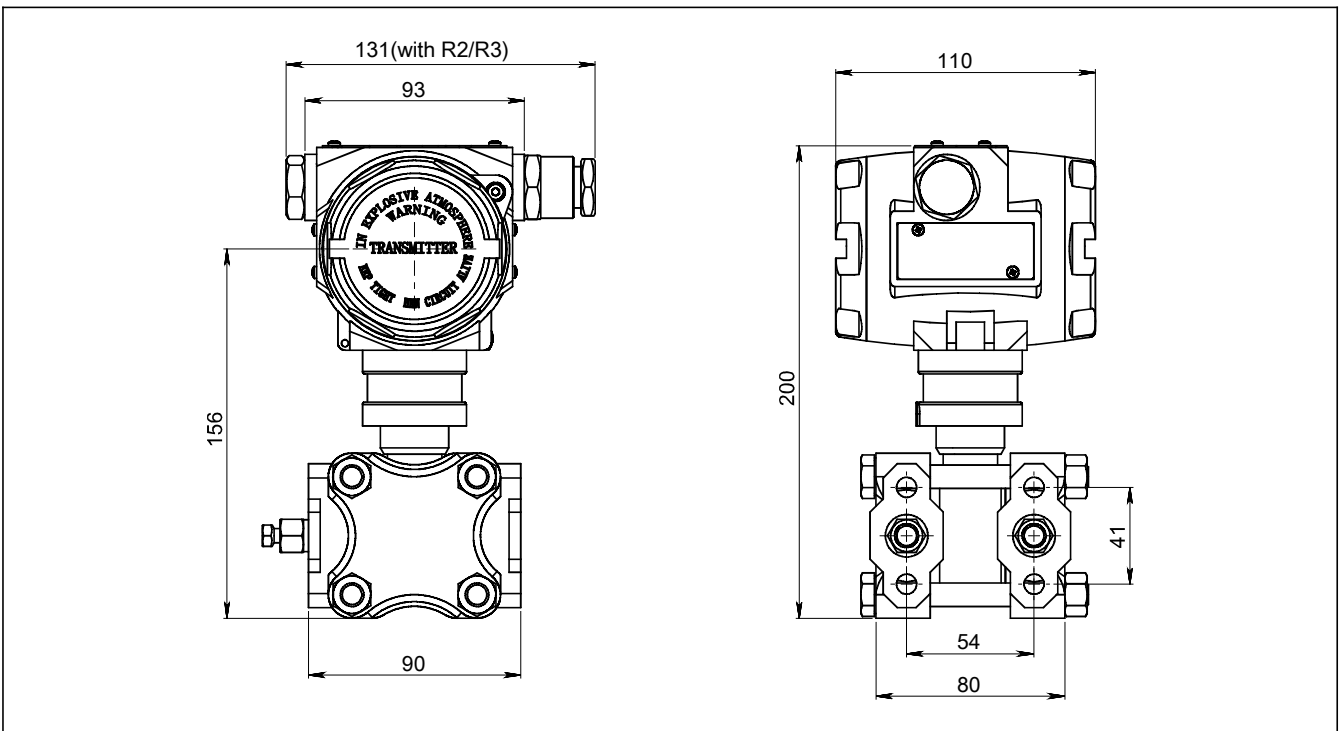

Disclaimer: all the data used in the product description is not legally binding. Relevant technical details may be changed due to further improve

Product drawing and dimension

Adaptor(A1) drawing and dimension(unit:mm)

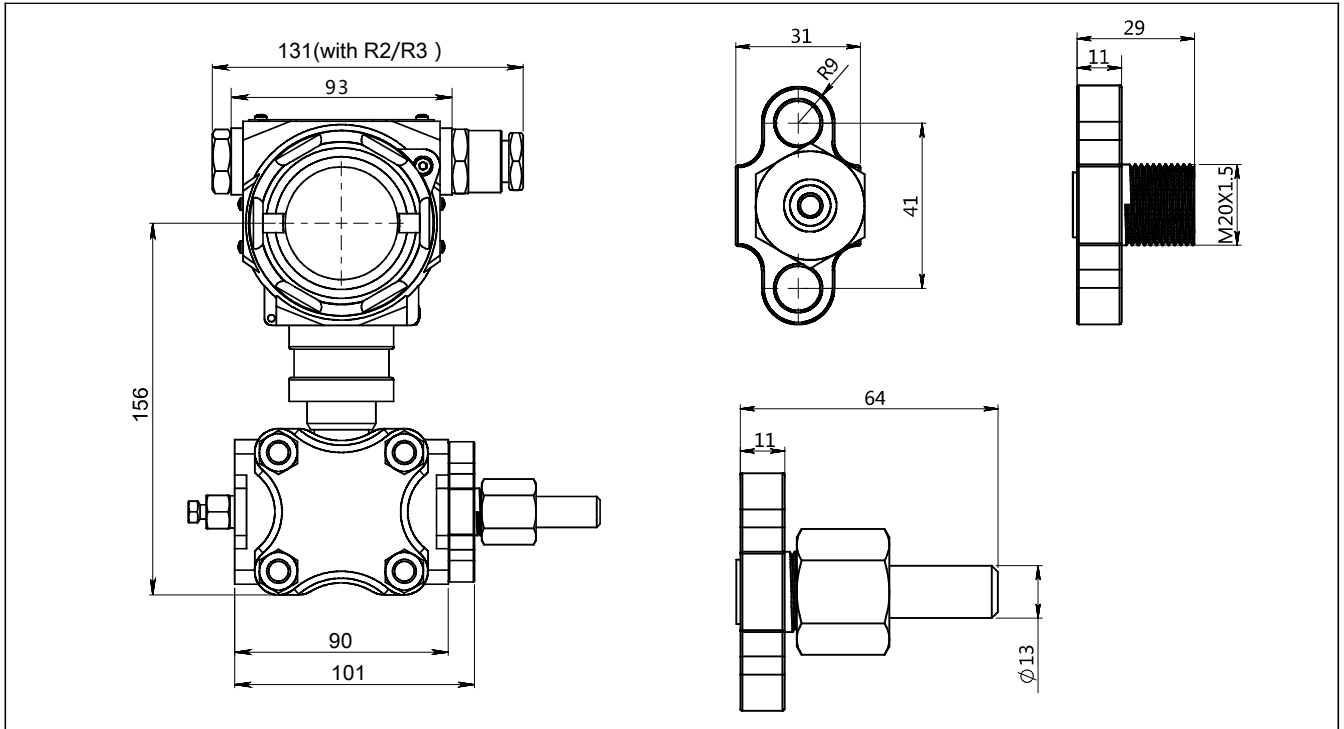

Adaptor(A2) drawing and dimension(unit:mm)

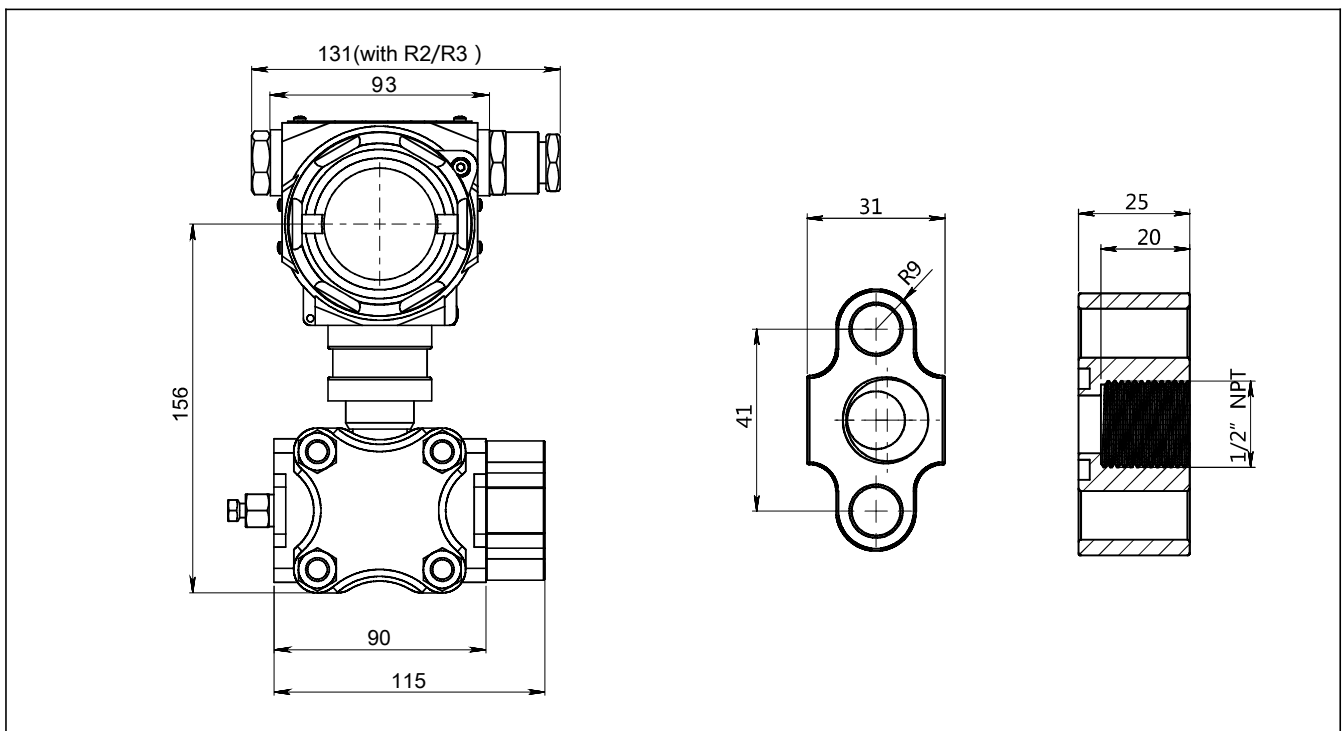

Disclaimer: all the data used in the product description is not legally binding. Relevant technical details may be changed due to further improve

Installation drawing and dimension

Pipe mounting bent bracket (B1) drawing and dimension (unit:mm)

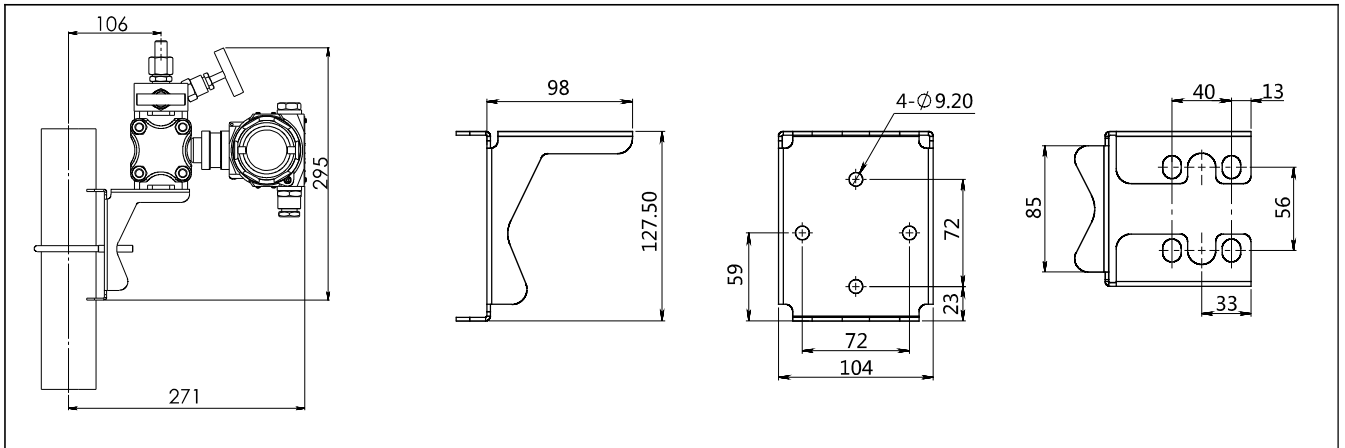
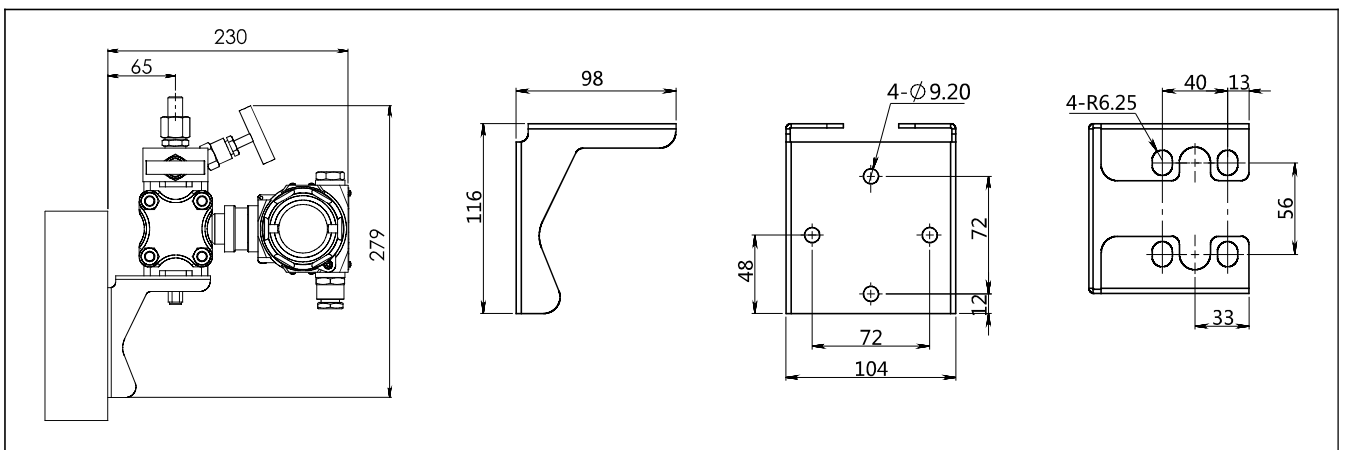
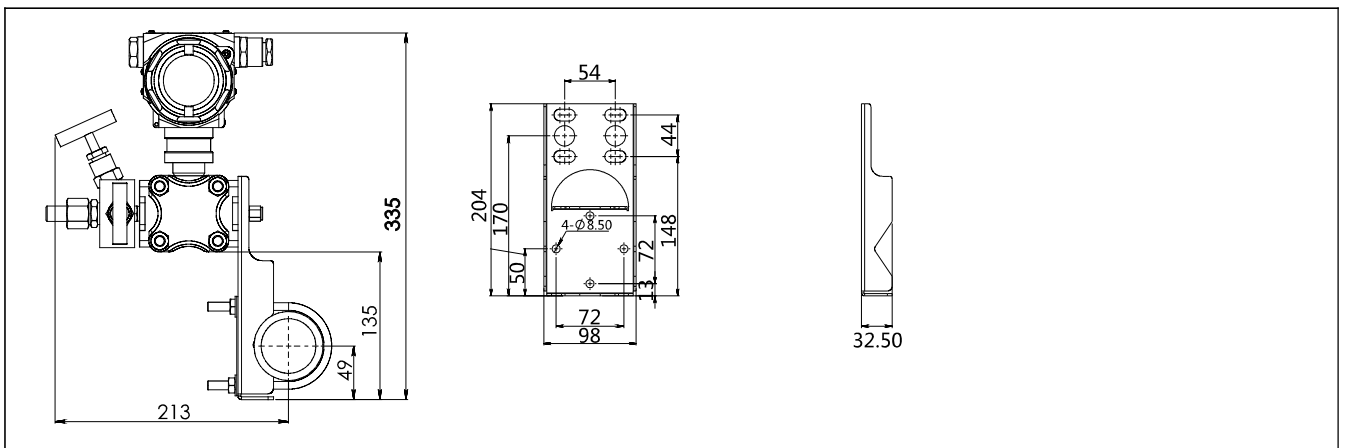

Plate mounting bent bracket(B2) drawing and dimension (unit:mm)



Pipe mounting flat bracket (B3) drawing and dimension (unit:mm)



Disclaimer: all the data used in the product description is not legally binding. Relevant technical details may be changed due to further improve

Ordering information chapter

Item	Parameters	Code	Instruction	(*)fast delivery available	
	Model	DMP305X-DST	Monosilicon differential pressure transmitter		
Sensor	Separator	-	Detailed specifications as following		
	Pressure range code	S602D	Nominal value(URL): 6kPa	*	
		S403D	Nominal value(URL): 40kPa	*	
		S254D	Nominal value(URL): 250kPa	*	
		S105D	Nominal value(URL): 1MPa		
		S305D	Nominal value(URL): 3MPa		
		S106D	Nominal value(URL): 10MPa		
	Diaphragm material	S	SUS316L		*
		H	Hastelloy C		
	Isolated filling fluid	S	Silicon oil filling, process temperature: -45-205°C		*
		D	Fluorocarbon oil filling, process temperature: -10-160°C		
Sensor seal	S	O-ring, FKM, process temperature: -20~200°C		*	
Electrical connection	Separator	-	Detailed specifications as following		
	Electrical connection	T1	Aluminum-alloy terminal,2 cable entry M20*1.5(F), red body, white cover	*	
	Cable entry protector	R1	Waterproof connector M20X1.5 one side , blind plug another side, PVC material,6-8mm diameter cable only, IP67	*	
		R2	Flame proof, 1/2 NPT(F) one side, blind plug another side, stainless steel material, 6-8mm diameter cable only, IP67		
		R3	Flame proof, M20X1.5(F) one side, blind plug another side, stainless steel material, 6-8mm diameter cable only, IP67	*	
Output	Separator	-	Detailed specifications as following		
	Output signal	H	4-20mA+HART two wire, power supply:16.5-55VDC	*	
		F	4-20mA two wire, power supply: 10.5-55VDC		
	Display	C	LCD display	*	
		A	Without LCD display		
Process connection	Separator	-	Detailed specifications as following		
	Process connection	H1	H structure, double flanges, process connection 1/4-18NPT(F) ,drain valve on the rear end of flange, material SS 316	*	
		H2	H structure, double flanges, process connection 1/4-18NPT(F), drain valve on the up part of flange, material SS 316		
		H3	H structure, double flanges, process connection 1/4-18NPT(F),drain valve on the down part of flange, material SS 316		

Selection

Additional options	Separator	-	Detailed specifications as following	(*)fast delivery available
	Process connection accessory	/A1	Adaptor, M20*1.5 (M) with pressure-guided pipe Φ 14*2*30, SS304, apply to H-structure	*
		/A2	Adaptor, 1/2-14NPT(F), SS 304, apply to H-structure	
	Fix mounting accessory	/B1	Pipe mounting bent bracket, 2" pipe, carbon steel, apply to H-structure	
		/B2	Plate mounting bent bracket, carbon steel, apply to H-structure	
		/B3	Pipe mounting flat bracket, 2" pipe, carbon steel, apply to H-structure	*
	Display mode	/D1	According to your requirement	
	Calibration report	/Q1	Calibration report provide by our company	
		/Q2	Calibration report provide by chinese authorised third party	
		/Q3	Static pressure report (Differential pressure only)	
	Approvals (Multiple)	/E1	Flame proof certificate, ExdIICT6, NEPSI	*
		/I1	Intrinsic safety certificate, ExialICT4, NEPSI	
		/F3	CE certificate	
	Wetted parts treatment	/G1	Ungrease treatment	
		/G2	Electropolishing treatment	

Factory settings and parameters

Item	Menu mark	Factory setting value
Tag position	None	0(No specific settings)
Analog output type	mA	Liner
Display mode	DISP	PV
Alarm signal	ALARM	No

Item	Menu mark	Factory setting value
Damping value	DAMP	0(No specific settings)
4mA Lower range value	LRV	According to the order value
20mA Upper range value	URV	According to the order value
Process unit	U	According to the order

Approvals

Factory certificate

Certification organization	Intertek
Quality management system	ISO9001-2008
Scope of certification	Design and production of pressure transmitter
Registration number	110804039

Intrinsic safety certificate

Certification organization name	NEPSI
License range	DMP305X series pressure/ differential pressure transmitter
Explosion-proof mark	ExiaIICT4
Ambient temperature	-40-+60°C
Medium maximum temperature	+120°C
Registration number	GYB16.1962X
Intrinsically safe parameter description	Maximum input voltage: 28VDC
	Maximum input current: 100mA
	Maximum input power: 0.7w
	Maximum internal equivalent parametersCi(uF): 0
	Maximum internal equivalent parametersLi(mH): 0.01

CE

Certificate organization	SET
License scope	DMP305X series pressure/ differential pressure transmitter
Mark	EU
EMC instruction	2014/30/EU
Standard	AC/0100708
Registration number	IT041353LG161207

Flame proof certificate

Certificate organization	NEPSI
License scope	DMP305X series pressure/ differential pressure transmitter
Explosion-proof mark	ExdIICT6
Working environmental temperature	-25-+60°C
Maximum medium temperature	+80°C
Registration number	GYB16.1254X

Shanghai LEEG Instruments Co.,Ltd

ADD: No.100 Duhui Road, Minhang District, Shanghai China
 Postcode:201109
 Tel: (86) 21-31261976
 Fax: (86) 21-31261975
 E-mail:sales@leegsensor.com info@leegsensor.com
 Web: www.leegsensor.com



scan & follow LEEG wechat



check website for more info