

Technical characteristics

- Flow rates: from 5.5 to 500 l/h
- Max Pressure: up to 16 bar (232 psi)
- Motor:
 - 0.18 kW - 3 ph (IP55)
 - 0.25 kW - 1 ph (IP55)
 - 0.37 kW - 3 ph or 1 ph (IP55)
 - 0.55 kW - 1 ph (IP55)
- Stroke rate: 58 – 78 – 116 strokes/minute
- Stroke length: 2 – 4 – 6 mm
- Diaphragm diameter: from 64 to 165 mm
- Pump head:
 - SS 316 L
 - PP
 - PVC
 - PVDF
- Max. dosing temperature:
 - SS 316 L 40° C
 - PP 40° C
 - PVC 40° C
 - PVDF 40° C
- Range of ambient temperature of use:
 - 5 ÷ 40° C

Seko mechanical diaphragm pump **MS1 Series** has a wide range product. MS1 Series performances cover s from 5.5 to 500 l/h with a back pressure up to 10 bar (in standard configuration, 16 bar for 064 and 094 models in “ENFORCED” configuration) having several configurations available for the pump head and power, in order to have the characteristics most suitable for processes where required.

MS1 pumps have a spring return mechanism into an aluminum housing.

Each model has 3 values of stroke rate, which can be set manually or automatically using a linear actuator which accepts a signal 4 – 20 mA. Moreover they can be supplied with a 3 phases or 1 phase electric motor with protection class IP55.

DOSING PUMP

SPRING SERIES – MS1 – Mechanical diaphragm pump



PUMP KEY CODE

Field 1	Field 2	Field 3	Field 4	Field 5	Field 6	Field 7	Field 8	Field 9	Field 10
M	S1	B	094	A	51	C4	0	0	0

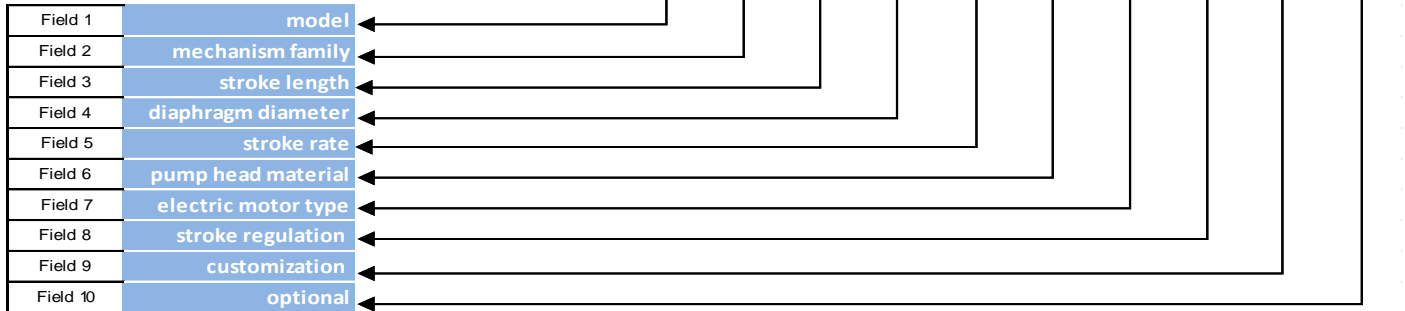

Field 1	model	M	<i>Diaphragm</i>
Field 2	mechanism family	S1	<i>Membrane</i>
Field 3	stroke length	A	<i>2 [mm]</i>
		B	<i>4</i>
		C	<i>6</i>
Field 4	diaphragm diameter	064	<i>64 [mm]</i>
		094	<i>94</i>
		108	<i>108</i>
		138	<i>138</i>
		165	<i>165</i>
Field 5	stroke rate	A	<i>58 [stroke/1']</i>
		B	<i>78</i>
		C	<i>116</i>
Field 6	pump head material		
		21	<i>SS316</i>
		31	<i>PVC</i>
		51	<i>PP</i>
		24	<i>SS316</i>
		41	<i>PVDF</i>
		52	<i>PP</i>
			<i>head</i>
			<i>diaphragm</i>
			<i>valves</i>
			<i>seat valves</i>
			<i>O-Ring</i>
			<i>on Ø 64</i>
			<i>on Ø 94 - 108</i>
			<i>on Ø 94 - 108</i>
			<i>on Ø 64</i>
			<i>on Ø 94 - 108</i>
			<i>on Ø 94 - 108</i>
Field 7	electric motor type	A4	<i>0,18 kW</i> (4 poles - 3phases 230-400 Vac 50/60 Hz - size 63-B14)
		C4	<i>0,37 kW</i> (4 poles - 3phases 230-400 Vac 50/60 Hz - size 71-B14)
		H4	<i>0,25 kW</i> (4 poles - 1phase 230 Vac 50 Hz - size 71-B14)
		L4	<i>0,55 kW</i> (4 poles - 1phase 230 Vac 50 Hz - size 80-B14)
		AI	<i>0,18 kW</i> (4 poles - 3phases 230-400 Vac 50/60 Hz - size 63-B14 - with INVERTER)
		CI	<i>0,37 kW</i> (4 poles - 3phases 230-400 Vac 50/60 Hz - size 71-B14 - with INVERTER)
		S0	<i>WITHOUT motor</i>
Field 8	stroke regulation	0	<i>Manual with adjustment knob - STANDARD</i>
		L	<i>Automatic Linear Actuator AKTUA series</i>
Field 9	customization	0	<i>Standard</i>
		H	<i>High Pressure</i>
Field 10	optional	0	<i>Standard</i>
		2	<i>(S0 - WITHOUT motor) + adapter kit</i>

DOSING PUMP

SPRING SERIES – MS1 – Mechanical diaphragm pump



HYDRAULIC CHARACTERISTICS

Pump Model	Ø Diaph. [mm]	Stroke/min	Flow rate		Max back pressure						Suction/Discharge Connection		Electric Motor 50 Hz 3 phases [kW]
					bar			p.s.i.					
			l/h	gl/h	SS 316	PP/PVC	PVDF	SS 316	PP/PVC	PVDF	SS 316	PP/PVC	
M S 1 A 0 6 4 A	64	58	5.5	1.45	16	10*	12*	232	145*	174*	1/4" G F	1/4" G F	0,18 (A4)
M S 1 A 0 6 4 B		78	8	2.12									
M S 1 A 0 6 4 C		116	11	2.91									
M S 1 A 0 9 4 A	94	58	20	5.59	16	10*	12*	232	145*	174*	3/8" G F	1/4" G F	0,18 (A4)
M S 1 A 0 9 4 B		78	26	6.88									
M S 1 A 0 9 4 C		116	40	10.58									
M S 1 B 1 0 8 A	108	58	60	15.87	10	10	10	145	145	145	3/8" G F	3/8" G F	0,18 (A4)
M S 1 B 1 0 8 B		78	80	21.16									
M S 1 B 1 0 8 C		116	120	31.75									
M S 1 C 1 3 8 A	138	58	155	41	7	7	7	101	101	101	3/4" G F	3/4" G F	0,37 (C4)
M S 1 C 1 3 8 B		78	220	58.2									
M S 1 C 1 3 8 C		116	310	82									
M S 1 C 1 6 5 A	165	58	230	60.85	5	5	5	72.5	72.5	72.5	1" G F	1" G F	0,37 (C4)
M S 1 C 1 6 5 B		78	330	87.30									
M S 1 C 1 6 5 C		116	500	132.3									

* Available with special reinforced pump head for use with pressure up to 16 bar - 14' Field (Optional) in the Key Code identified by "H"

DIMENSIONS

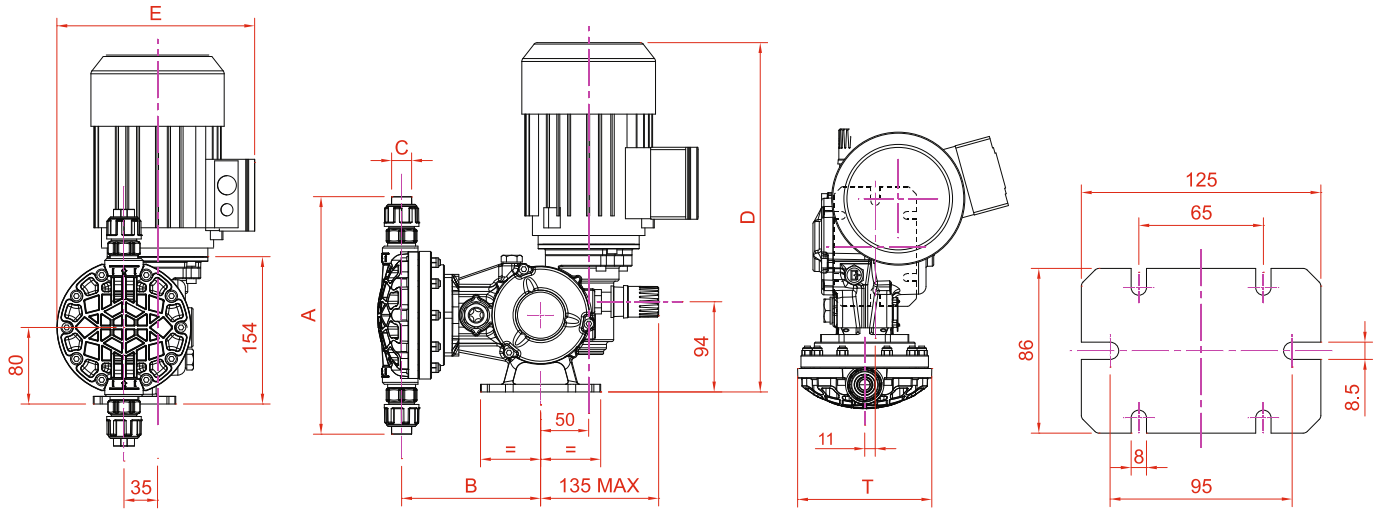

Materiale testata Liquid end material	Diametro membrana Diaphragm diameter	A[mm]	B[mm]	C (BSP)	T[mm]	Three phase motor				Single phase motor			
						Motore 4P Motor 4P [kW]	Gr. motore Motor Size	D [mm]	E [mm]	Motore 4P Motor 4P [kW]	Gr. motore Motor Size	D [mm]	E [mm]
AISI 316 (21)	65	192	144	1/4" f	98	0.18	63 B14	333	240	0.25	71 B14	371	343
	94	172	146	3/8" f	118	0.18	71 B14	371	250	0.25	71 B14	371	346
	108	213	148	3/8" f	138	0.18	71 B14	371	265	0.25	80 B14	396	379
	138	261	158	3/4" f - 1" f	168	0.37	71 B14	371	265	0.55	80 B14	396	394
	165	297	165	1" f	188	0.37	71 B14	371	265	0.55	80 B14	396	414
PP (51) PVC (31) PVDF (41)	65	239	149	1/4" f	98	0.18	63 B14	333	240	0.25	71 B14	371	348
	94	242	144	3/8" f	124	0.18	71 B14	371	250	0.25	71 B14	371	351
	108	250	147	3/8" f	142	0.18	71 B14	371	265	0.25	80 B14	396	385
	138	347	159	3/4" f - 1" f	166	0.37	71 B14	371	265	0.55	80 B14	396	406
PP (51)	165	375	172	1" f	195	0.37	71 B14	371	265	0.55	80 B14	396	416
PVC (31), PVDF (41)	165	375	172	1" f	195	0.37	71 B14	371	265	0.55	80 B14	396	414

DOSING PUMP

SPRING SERIES – MS1 – Mechanical diaphragm pump

